

SINCE 1908
wessels
 company

SUBMITTAL

TYPE: TWIN GMP SERIES
 GLYCOL MAKE-UP PACKAGE

Submittal Sheet No. M-3233 Date 7/01

JOB _____	Wessels Representative _____	
Unit Tag No. _____	Order No. _____	Date _____
Engineer _____	Submitted By _____	Date _____
Contractor _____	Approved By _____	Date _____

**TWIN GLYCOL MAKE-UP PACKAGE
 WITH ALTERNATOR**

Fully automated and autonomous. Complete with: low level cut-off and alarm arrangement including a 110V signal for remote alarm, isolation valves, strainer, pressure tank with pressure control, pressure reducing valve and gauge, translucent polyethylene solution container with lid designed to accommodate relief valve piping, control panel with alternator, two magnetic starters, 110V, 60Hz motors and controls. All mounted on a sturdy steel frame with 1/2" system connection and factory preset 12 psig (field adjustable) discharge.

GMPT-33050 & 33100 - 1/3 HP
 GMPT-35050 & 35100 - 1/2 HP

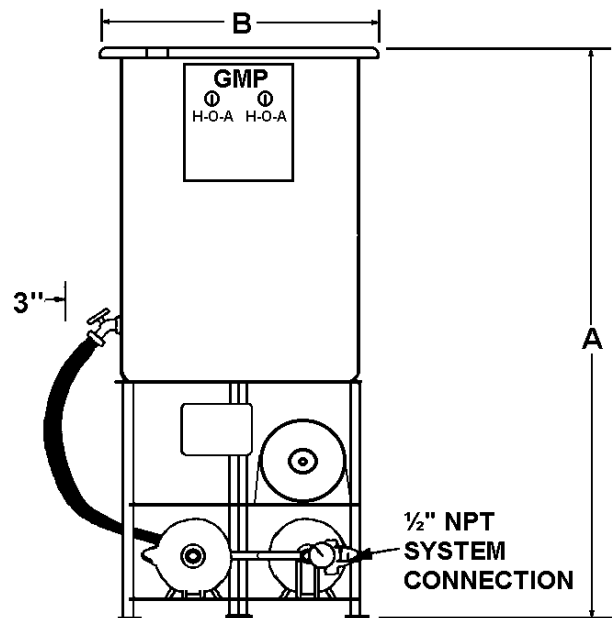

Model Number	Make-Up Capacity (gpm @ psi)	Pressure Range (psi)	Solution Container (gal)	Dimensions (inches)		Approx. Weight (lbs.)
				A	B	
GMPT-33050	1.8 @ 50	10 - 50	50	52	34	200
GMPT-33100	1.8 @ 50	10 - 50	100	76	34	216
GMPT-35050	1.7 @ 70	10 - 70	50	52	34	206
GMPT-35100	1.7 @ 70	10 - 70	100	76	34	222

NOTE: Please consult factory for other sizes and/or models.

QUANTITY MODEL
 _____ GMPT - _____